

# DETACHED DOUBLE-GLASS PATIO COVER WITH 5.52KW DC SOLAR

## SCOPE OF WORK

This project involves constructing a steel framed patio cover utilizing a moment frame design and supporting a 12 solar panels directly onto cold-formed steel trusses.

The trusses are comprised two galvanized cold-formed steel studs which are then enclosed with galvanized structural track on the top and the bottom. The boxed beams form a channel to enclose PV wiring and to directly support the PV panels (modules) fully along their long edges.

The panels are bifacial (double glass) panels which allow some light to pass through as well as collecting solar energy from the underside of the panels.

Separate structural calculations are provided for the patio cover.

The inverter is a hybrid PV and Battery Inverter. Even if batteries are not included the inverter makes the system battery and off-grid capable with the addition of a few components including the batteries.

**Approximate Patio Cover Area**      **270 Sq. Ft.**  
**Rated DC Solar Output Power**      **5.52 KW DC**  
**Standard Test Conditions Power**      **4.91 KW AC**

## SHEET INDEX

- 1 Title Page
- 2 Isometric Views
- 3 Structural Side View
- 4 Structural Front View
- 5 Structural Rear View

## RENDERING

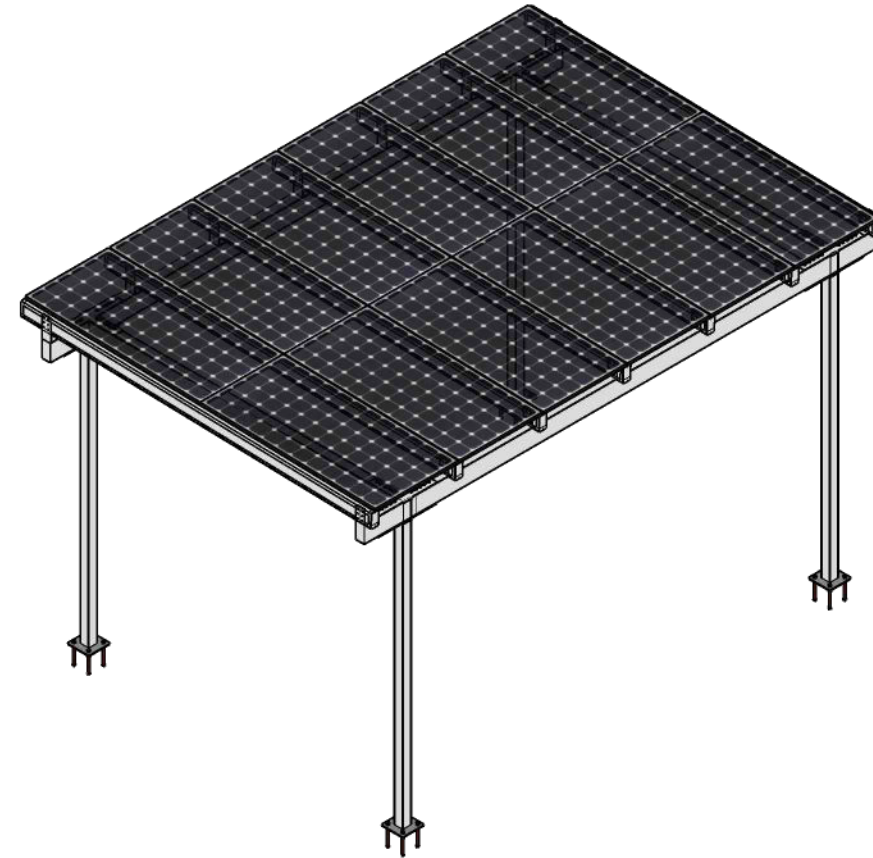

## REFERENCED CODES

2019 California Electrical Code  
 2020 National Electric Code NEC)  
 2019 California Residential Code (CRC)  
 2019 California Building Code (CBC)  
 2019 California Fire Code

**This structure is rated as IBC Building Occupancy Group U - Utility and Miscellaneous.**

TITLE PAGE

CONFIDENTIAL - THE INFORMATION CONTAINED HEREIN SHALL NOT BE USED FOR THE BENEFIT OF ANYONE BESIDES SOLAR POWER PATIOS. NOR SHALL IT BE DISCLOSED IN WHOLE OR IN PART TO OTHERS OUTSIDE RECIPIENTS ORGANIZATION EXCEPT IN CONNECTION WITH THE SALE AND USE OF THE RESPECTIVE EQUIPMENT WITHOUT THE WRITTEN PERMISSION OF SOLAR POWER PATIOS.



SOLAR POWER PATIOS  
 CSLB C-10 & A LICENSE #1011915

### REVISIONS

DDMMYYYY	REMARKS
1 19JUL2021	Revision 1 - K Anderson - Initial release
2 ---/---/---	...
3 ---/---/---	...
4 ---/---/---	...
5 ---/---/---	...

REV1 01

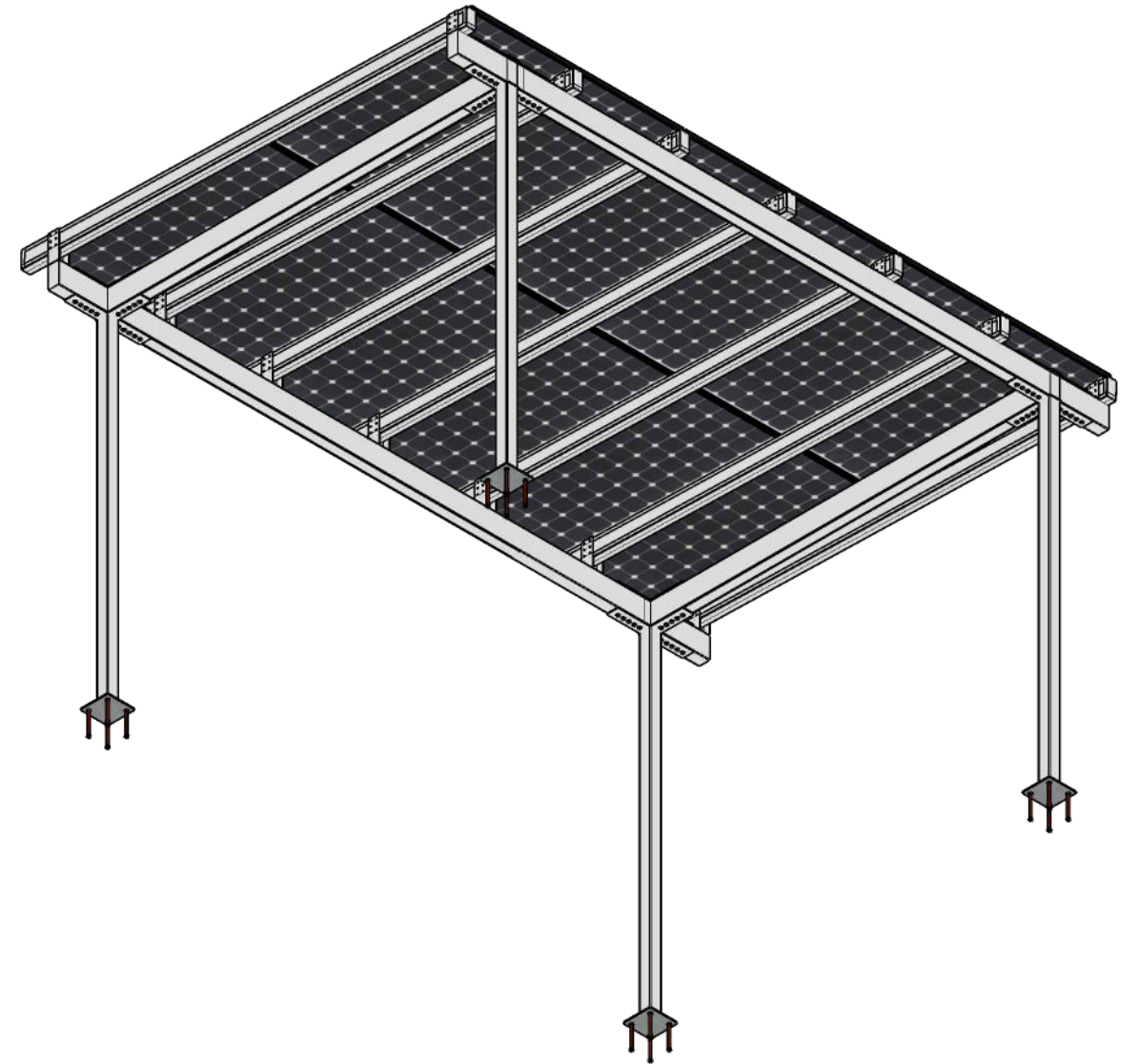
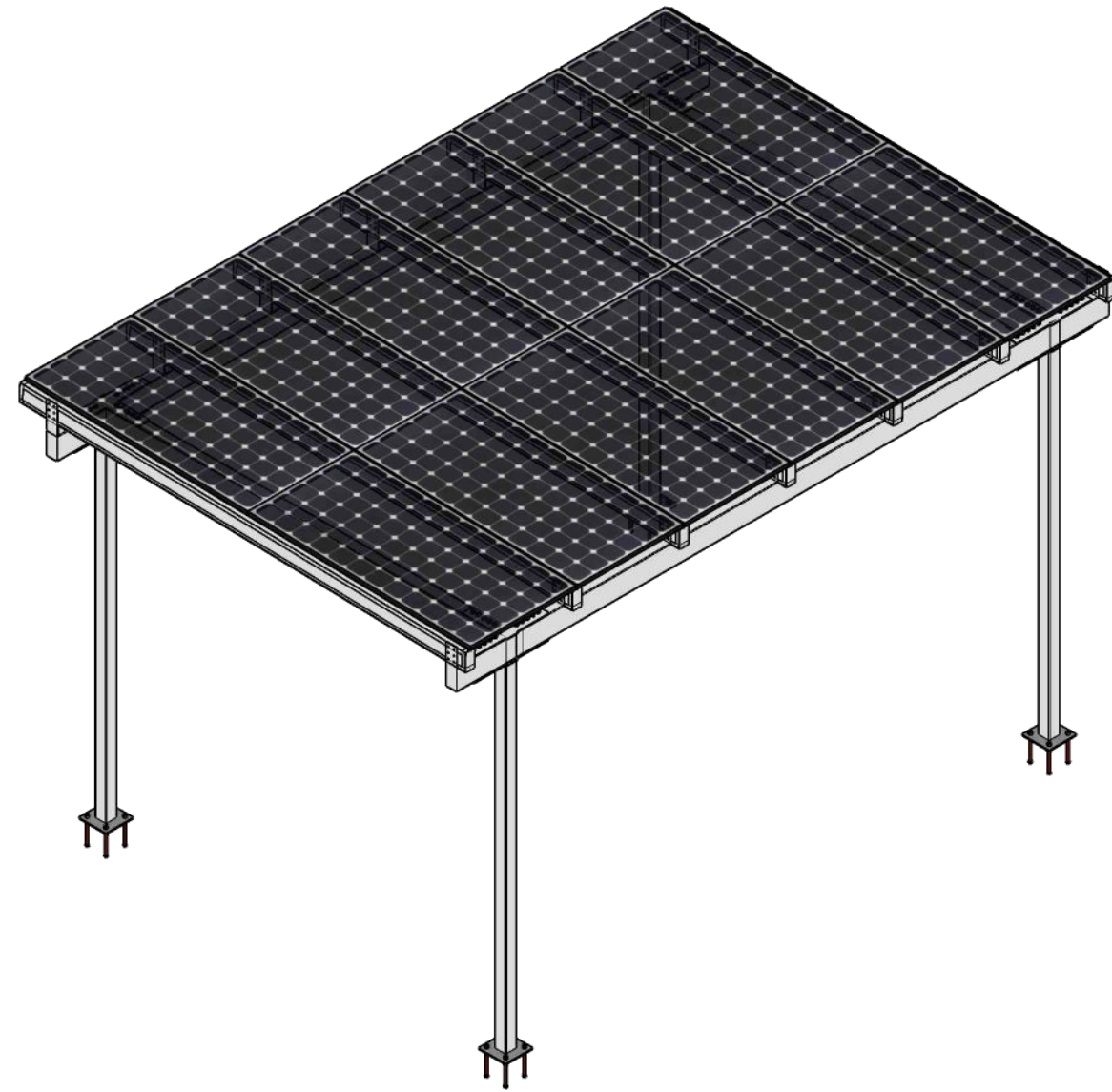

**ARCHITECTURAL TOP & UNDERSIDE VIEW**

Scale 1/4" = 1 Foot (1:48)

CONFIDENTIAL - THE INFORMATION CONTAINED HEREIN SHALL NOT BE USED FOR THE BENEFIT OF ANYONE BESIDES SOLAR POWER PATIOS. NOR SHALL IT BE DISCLOSED IN WHOLE OR IN PART TO OTHERS OUTSIDE RECIPIENTS ORGANIZATION EXCEPT IN CONNECTION WITH THE SALE AND USE OF THE RESPECTIVE EQUIPMENT WITHOUT THE WRITTEN PERMISSION OF SOLAR POWER PATIOS.



SOLAR POWER PATIOS  
 CSLB C-10 & A LICENSE #1011915

REVISIONS	
DDMMYYYY	REMARKS
1 19JUL2021	Revision 1 - K Anderson - Initial release
2 ---/---/---	...
3 ---/---/---	...
4 ---/---/---	...
5 ---/---/---	...

REV1 02

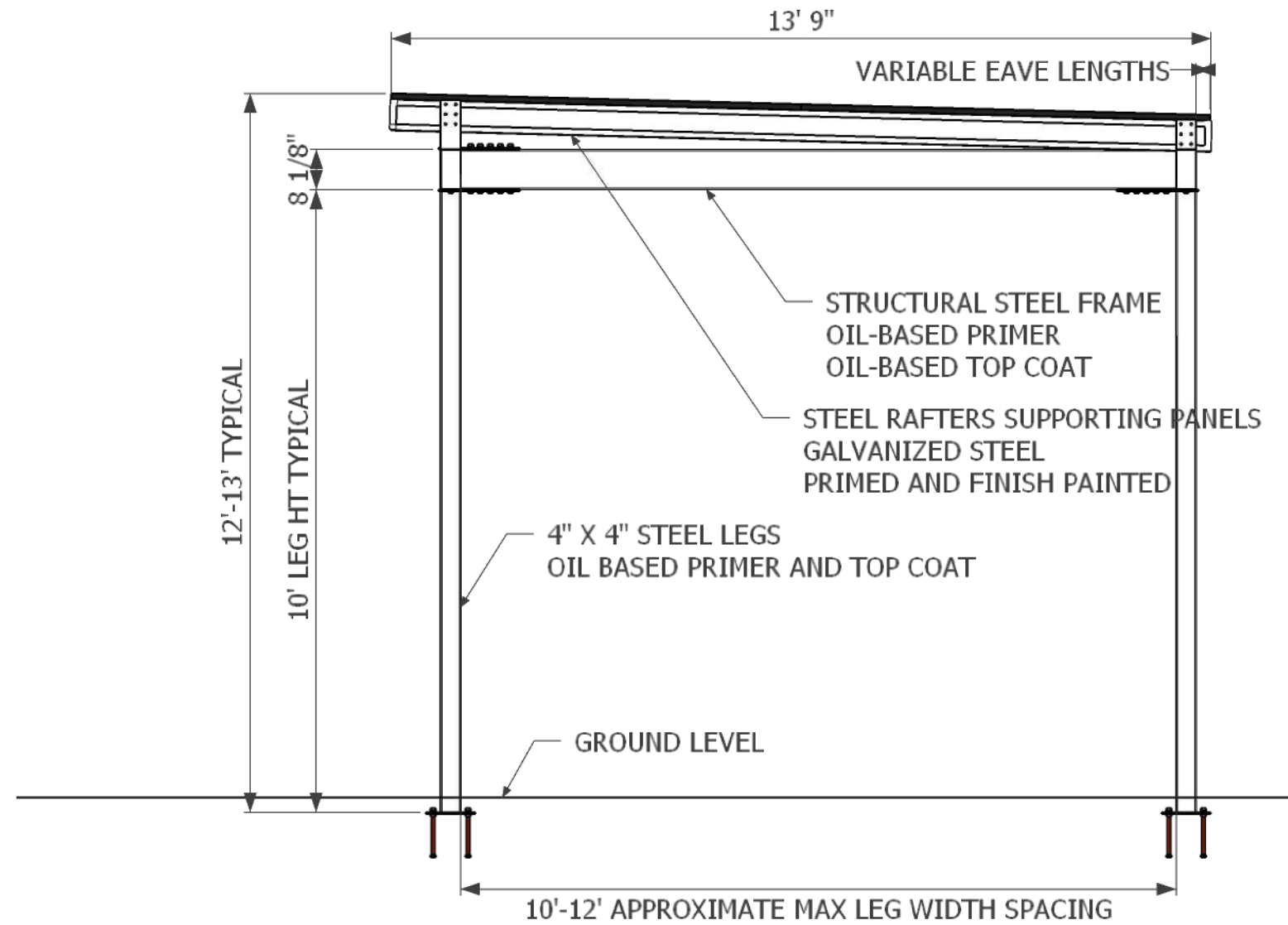

**STRUCTURAL SIDE VIEW**

Scale 3/8" = 1 Foot (1:32)

CONFIDENTIAL - THE INFORMATION CONTAINED HEREIN SHALL NOT BE USED FOR THE BENEFIT OF ANYONE BESIDES SOLAR POWER PATIOS. NOR SHALL IT BE DISCLOSED IN WHOLE OR IN PART TO OTHERS OUTSIDE RECIPIENTS ORGANIZATION EXCEPT IN CONNECTION WITH THE SALE AND USE OF THE RESPECTIVE EQUIPMENT WITHOUT THE WRITTEN PERMISSION OF SOLAR POWER PATIOS.



SOLAR POWER PATIOS  
CSLB C-10 & A LICENSE #1011915

REVISIONS	
DDMMYYYY	REMARKS
19JUL2021	Revision 1 - K Anderson - Initial release
...	...
...	...
...	...
...	...

REV1 03

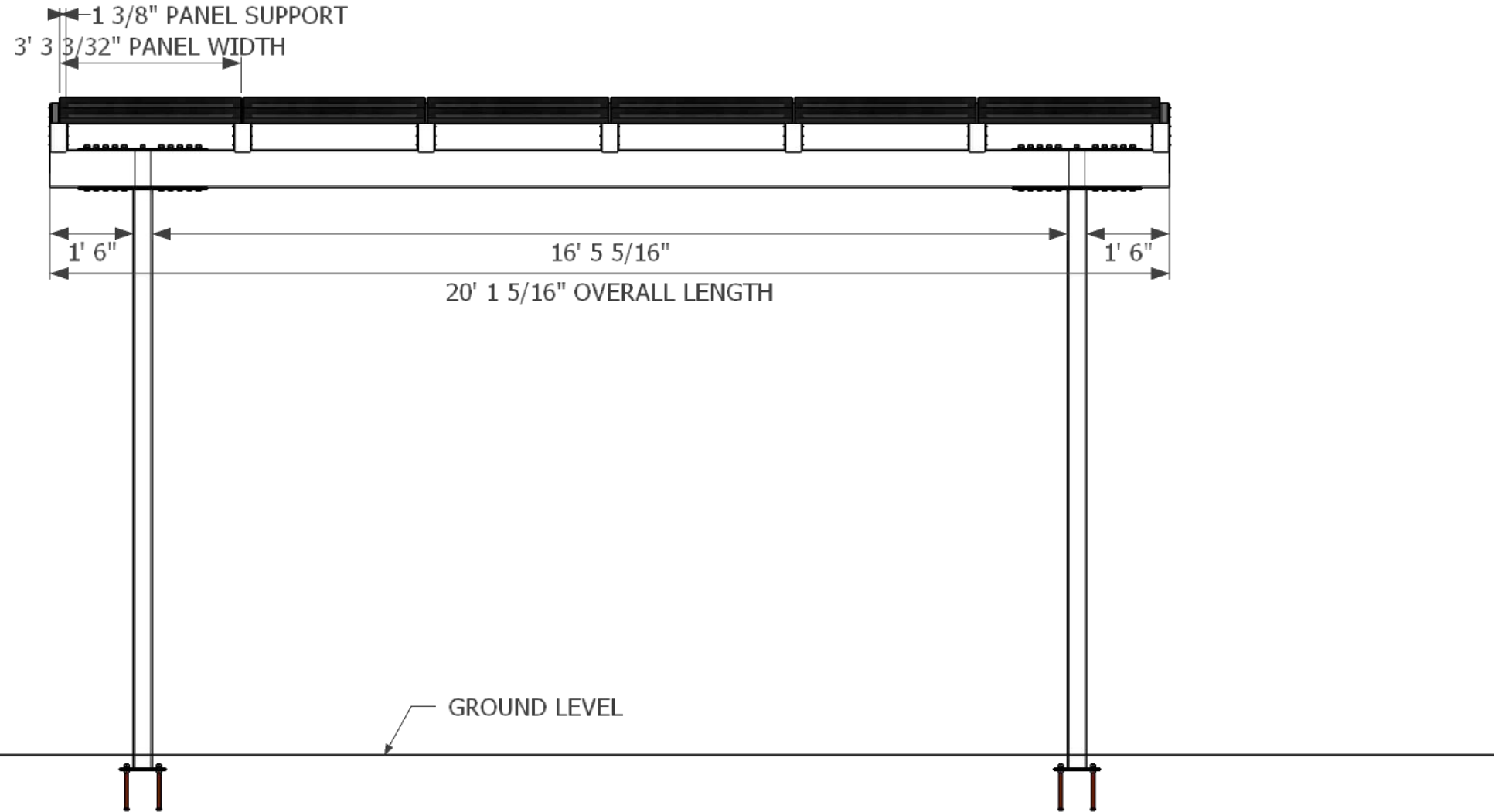

**STRUCTURAL FRONT VIEW**

Scale 3/16" = 1 Foot (1:32)

CONFIDENTIAL - THE INFORMATION CONTAINED HEREIN SHALL NOT BE USED FOR THE BENEFIT OF ANYONE BESIDES SOLAR POWER PATIOS. NOR SHALL IT BE DISCLOSED IN WHOLE OR IN PART TO OTHERS OUTSIDE RECIPIENTS ORGANIZATION EXCEPT IN CONNECTION WITH THE SALE AND USE OF THE RESPECTIVE EQUIPMENT WITHOUT THE WRITTEN PERMISSION OF SOLAR POWER PATIOS.



SOLAR POWER PATIOS  
 CSLB C-10 & A LICENSE #1011915

REVISIONS	
DDMMYYYY	REMARKS
1 19JUL2021	Revision 1 - K Anderson - Initial release
2 ---/---/---	...
3 ---/---/---	...
4 ---/---/---	...
5 ---/---/---	...

REV1 04

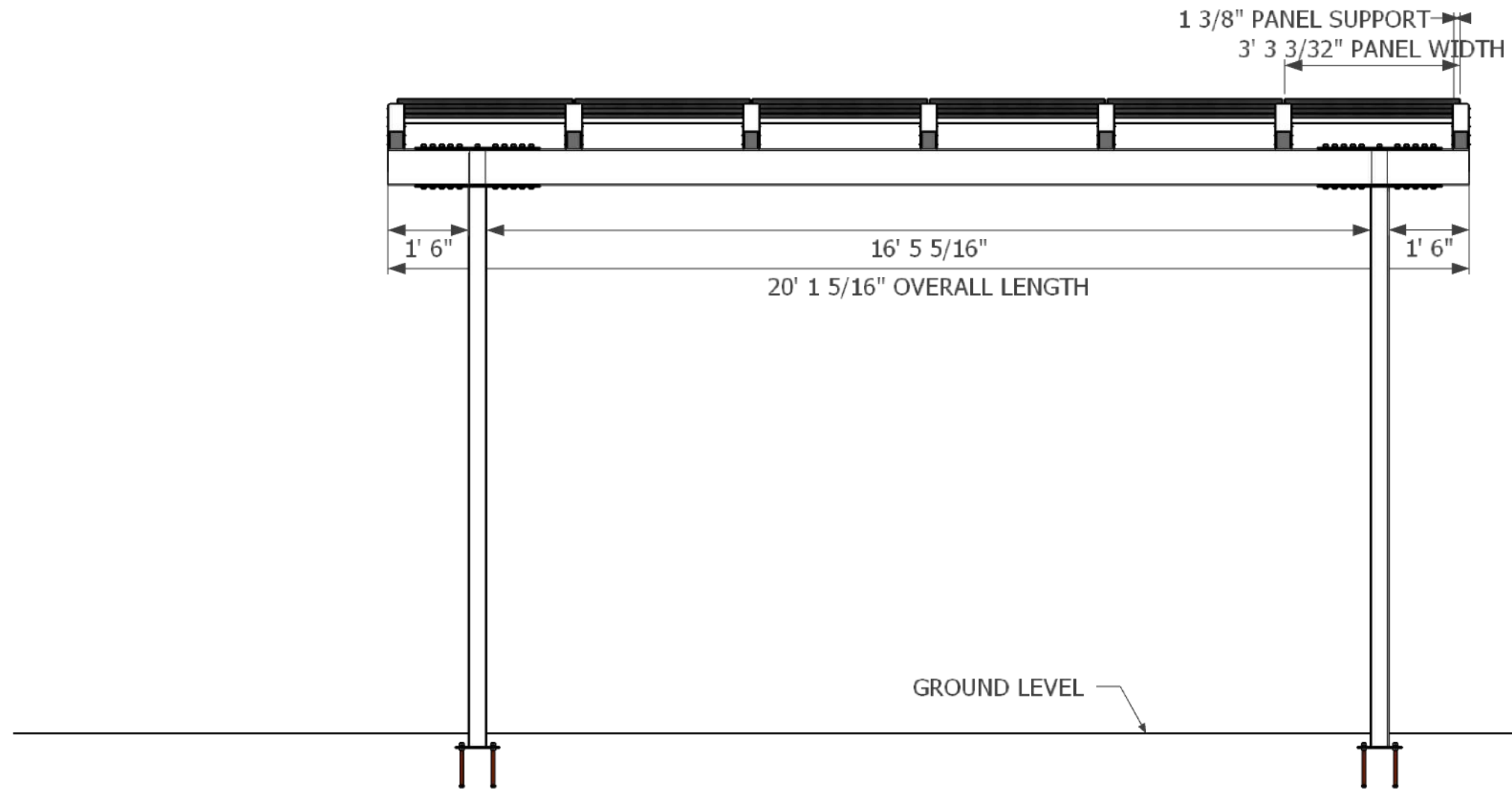

**STRUCTURAL REAR VIEW**

Scale 3/16" = 1 Foot (1:32)

CONFIDENTIAL - THE INFORMATION CONTAINED HEREIN SHALL NOT BE USED FOR THE BENEFIT OF ANYONE BESIDES SOLAR POWER PATIOS. NOR SHALL IT BE DISCLOSED IN WHOLE OR IN PART TO OTHERS OUTSIDE RECIPIENTS ORGANIZATION EXCEPT IN CONNECTION WITH THE SALE AND USE OF THE RESPECTIVE EQUIPMENT WITHOUT THE WRITTEN PERMISSION OF SOLAR POWER PATIOS.



SOLAR POWER PATIOS  
 CSLB C-10 & A LICENSE #1011915

REVISIONS		
DDMMYYYY	REMARKS	
1 19JUL2021	Revision 1 - K Anderson - Initial release	
2	...	
3	...	
4	...	
5	...	

REV1 05